



Cambridge International Examinations
Cambridge International General Certificate of Secondary Education

CANDIDATE
NAME

CENTRE
NUMBER

--	--	--	--	--

CANDIDATE
NUMBER

--	--	--	--

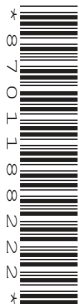

CO-ORDINATED SCIENCES

Paper 4 Theory (Extended)

0654/43

May/June 2018

2 hours

Candidates answer on the Question Paper.

No Additional Materials are required.

READ THESE INSTRUCTIONS FIRST

Write your Centre number, candidate number and name on all the work you hand in.

Write in dark blue or black pen.

You may use an HB pencil for any diagrams or graphs.

Do not use staples, paper clips, glue or correction fluid.

DO NOT WRITE IN ANY BARCODES.

Answer **all** questions.

Electronic calculators may be used.

You may lose marks if you do not show your working or if you do not use appropriate units.

A copy of the Periodic Table is printed on page 32.

At the end of the examination, fasten all your work securely together.

The number of marks is given in brackets [] at the end of each question or part question.

This document consists of **28** printed pages and **4** blank pages.

1 Fig. 1.1 shows a photograph of cross-sections of an artery and a vein.

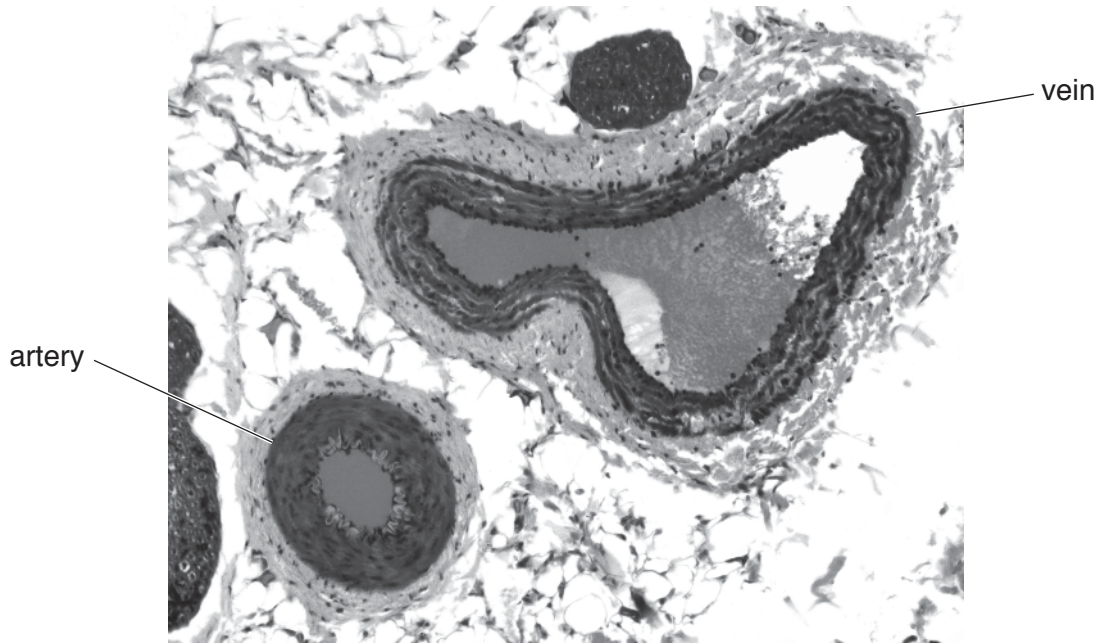

Fig. 1.1

(a) (i) Describe how the lumen of the artery differs from the lumen of the vein.

.....
.....
..... [2]

(ii) Explain why the wall of the artery is thicker than the wall of the vein.

.....
..... [1]

(iii) One structure found in veins is not shown in Fig. 1.1.

Name this structure **and** explain its function.

structure

function

.....
.....

[2]

(b) Fig. 1.2 shows information about three different people.

person A	person B	person C
<ul style="list-style-type: none">• age 32• below average weight• plays football twice a week• non-smoker	<ul style="list-style-type: none">• age 65• above average weight• works in an office• non-smoker	<ul style="list-style-type: none">• age 72• very overweight• heavy smoker• takes no exercise

Fig. 1.2

(i) Using information from Fig. 1.2, state which person is **most** at risk from developing coronary heart disease.

Explain your answer.

.....
.....[1]

(ii) State **two** other risk factors for coronary heart disease that are not shown in the information in Fig. 1.2.

1

2 [2]

(iii) Suggest **two** ways in which **person B** in Fig. 1.2 could reduce their risk of developing coronary heart disease.

1

2 [2]

- 2 (a) (i) Name the collection of metals in the Periodic Table that includes copper.

..... [1]

- (ii) State **two** properties of copper that are not typical of the metals in Group I and Group II in the Periodic Table.

1

2 [2]

- (b) The formula of copper(II) chloride is CuCl_2 .

The formula of copper(I) chloride is CuCl .

Copper(II) chloride decomposes at a high temperature.

The balanced equation for this decomposition is shown below.

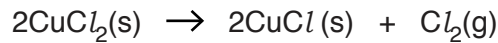

- (i) State **and** explain which substance shown in this equation is an *element*.

element

explanation

..... [2]

- (ii) Copper(I) chloride contains copper ions and chloride ions.

A chloride ion has the formula Cl^- .

Deduce the formula of a copper ion in CuCl .

Explain your answer.

formula

explanation

..... [2]

- (c) Zinc displaces copper from copper sulfate.

The ionic equation for this reaction is shown below.

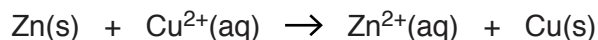

- (i) State the meanings of the symbols (*aq*) and (*s*).

(aq)

(s)

[1]

- (ii) Describe **one** observation during the reaction between zinc and copper sulfate.

.....

.....[1]

- (iii) Explain why this displacement reaction occurs.

.....

.....[1]

- (iv) Use the information in the ionic equation to explain, in terms of electrons, which particle is oxidised and which is reduced.

formula of particle which is oxidised

formula of particle which is reduced

explanation

.....

[2]

- 3 (a) Fig. 3.1 shows an astronaut driving a vehicle on the Moon.

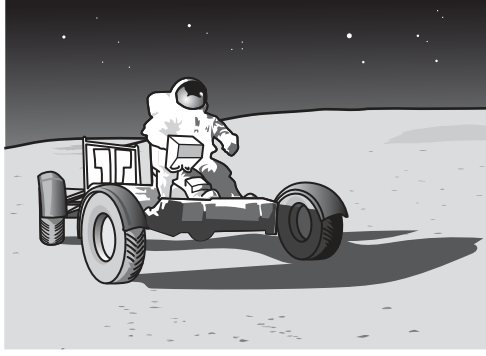

Fig. 3.1

The vehicle and astronaut have a total mass of 300 kg.

On the Moon, the gravitational field strength is 1.6 N/kg.

- (i) Calculate the total weight of the vehicle and astronaut on the Moon.

weight = N [1]

- (ii) The vehicle accelerates. Calculate the acceleration if the force applied is 600 N.

State the formula you use, show your working and state the units of your answer.

formula

working

acceleration = units [3]

- (b) The astronaut remains in communication with Earth from the Moon using radio waves.

Radio waves have a frequency of 90.3×10^6 Hz and a wavelength of 3.32 m.

- (i) Show that the average speed of the radio waves is 300×10^6 m/s.

State the formula you use and show your working.

formula

working

[2]

(ii) The Moon is 400 000 km from Earth.

Calculate the time it takes for radio waves from the Moon to reach the Earth.

State the formula you use and show your working.

formula

working

time = s [2]

(iii) Place radio waves in the correct box in the incomplete electromagnetic spectrum in Fig. 3.2.

		ultraviolet	visible light		microwaves	
--	--	-------------	---------------	--	------------	--

Fig. 3.2

[1]

(iv) Explain why it would not be possible for the astronaut to communicate with Earth using sound waves.

.....
.....
.....[1]

- 4 Fig. 4.1 is a drawing of a leaf. The white section of the leaf contains no chlorophyll and so does not photosynthesise.

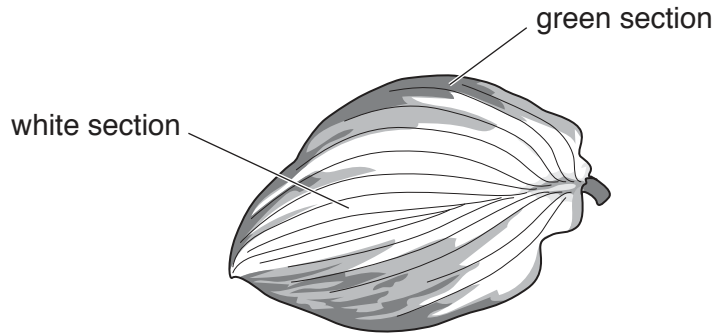

Fig. 4.1

- (a) (i) Explain why chlorophyll is necessary for photosynthesis.

Use the word **energy** in your answer.

.....

.....

.....

.....

..... [3]

- (ii) State the **balanced symbolic** equation for photosynthesis.

..... [2]

- (b) Mineral ions are needed for healthy plant growth.

Table 4.1 shows the function and the effect of deficiency of some mineral ions on plants.

Complete Table 4.1.

Table 4.1

mineral ion	function	effect of deficiency
		yellowing of leaves
	protein synthesis	

[4]

5 Lithium is a metal in Group I of the Periodic Table.

(a) A piece of lithium is added to a neutral, aqueous solution of full-range indicator (Universal Indicator).

(i) State the final colour of the indicator that suggests that a solution of lithium hydroxide, LiOH, forms.

.....[1]

(ii) The reaction between lithium and water also produces hydrogen gas.

Construct the **balanced symbolic** equation for this reaction.

.....[2]

(b) Fig. 5.1 shows the apparatus used for the electrolysis of lithium chloride.

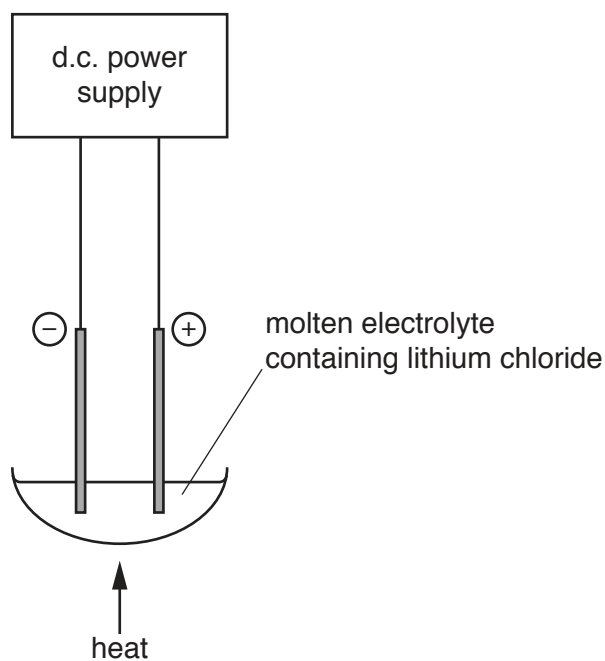

Fig. 5.1

(i) Explain why electrolysis occurs **only** when the electrolyte is in the form of a liquid.

.....
[1]

- (ii) State **and** explain to which electrode, anode or cathode, lithium ions move during electrolysis.

electrode

explanation

..... [1]

- (iii) Describe, in terms of ions and electrons, how lithium atoms are formed during electrolysis.

.....

.....

..... [2]

- 6 (a) Fig. 6.1 shows a car travelling at 5 m/s passing another car also travelling at 5 m/s. The direction in which each car is travelling is shown by the arrows.

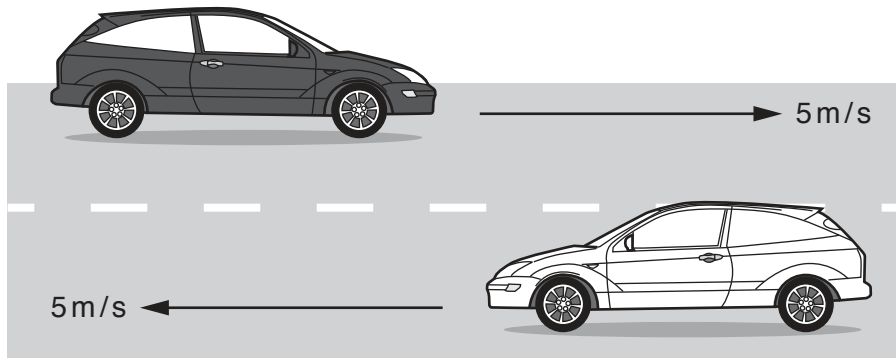

Fig. 6.1

Explain why the cars have the same speeds but not the same velocities.

.....

 [1]

- (b) During a journey, a car travels 2000 m along a straight road in 120 s. The driving force of the car’s engine is 12000 N.

- (i) Calculate the work done by the driving force.

State the formula you use and show your working.

formula

working

work done = J [2]

- (ii) Calculate the useful power output from the car’s engine during this period.

State the formula you use and show your working.

formula

working

power = W [2]

(c) Some puddles of water have formed on the road after rainfall.

State **and** explain, in terms of water molecules, how the rate of evaporation is affected by an increase in water temperature.

.....

.....

.....

..... [2]

7 Fig. 7.1 is a diagram of a growing baby (fetus) during pregnancy.

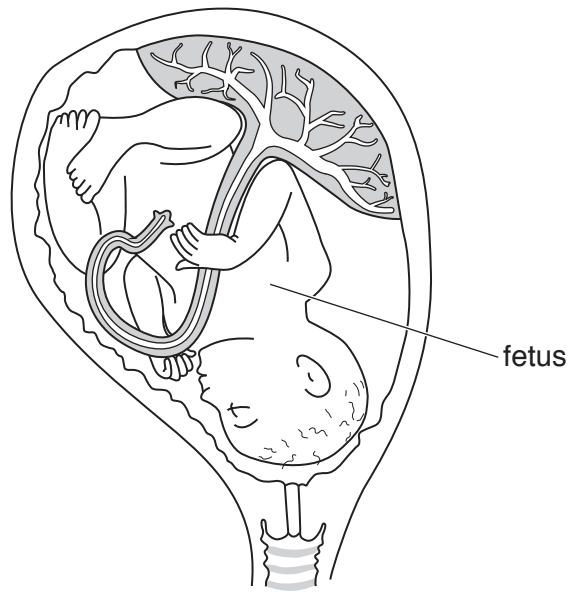

Fig. 7.1

(a) Draw a label line and the letter **X** to identify the placenta in Fig. 7.1. [1]

(b) The boxes on the left show some of the parts seen in Fig. 7.1.

The boxes on the right show the functions of these parts.

Draw **four** lines to link each part with its correct function.

part	function
amniotic fluid	transports nutrients and waste between fetus and mother
amniotic sac	keeps fetus in place during pregnancy
cervix	contains amniotic fluid
umbilical cord	protects fetus from bumps and knocks

[3]

- (c) The placenta is a site of gas exchange. It shares many features with alveoli, the site of gas exchange in the lungs.

Suggest **two** features that both the placenta and alveoli have to enable efficient gas exchange.

1

2

[2]

- (d) Substances are transferred between the mother and fetus by diffusion at the placenta.

Table 7.1 shows some of the substances that pass between the mother and the fetus.

Place a tick (✓) in the boxes to identify the direction of net movement of these substances.

Table 7.1

substance	pass from mother to fetus	pass from fetus to mother
amino acids		
carbon dioxide		
glucose		
oxygen		
urea		

[2]

8 (a) Brass is a mixture of copper and zinc.

(i) State the term used for a mixture of metals.

.....[1]

(ii) State **one** physical property, other than colour, that will be different in brass and copper.

.....[1]

(iii) Steel is a mixture containing iron.

Steel is galvanised by covering it with a thin layer of zinc.

Explain why galvanising protects steel from rusting even when the layer of zinc gets damaged.

.....

[2]

(b) A teacher adds 13.0g of zinc to 0.4 dm³ of 0.2 mol/dm³ sulfuric acid, as shown in Fig. 8.1.

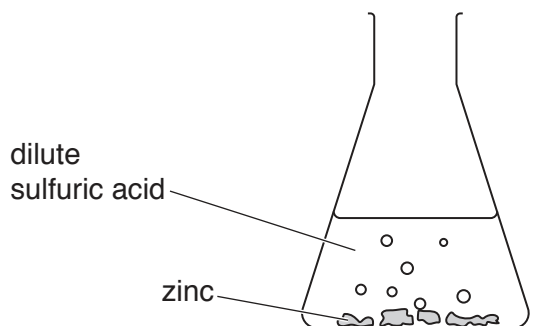
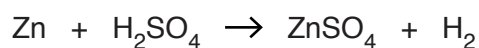

Fig. 8.1

The balanced equation for this reaction is shown below.



Complete steps **1**, **2** and **3** to deduce whether there is enough sulfuric acid to react with **all** of the zinc.

Step 1

Calculate the number of moles of zinc contained in 13.0g.

[A_r : Zn, 65]

number of moles =

Step 2

Calculate the number of moles of sulfuric acid contained in 0.4 dm^3 of 0.2 mol/dm^3 sulfuric acid.

number of moles =

Step 3

Use the balanced equation and your answers to step 1 and step 2 to deduce whether there is enough sulfuric acid to react with **all** of the zinc.

.....

.....

[3]

(c) Describe a chemical test and its result to show that an aqueous solution contains sulfate ions.

test

result

[2]

- 9 (a) (i) An isotope of aluminium has a nuclide notation ${}_{13}^{28}\text{Al}$ and decays by beta (β) emission to produce an isotope of silicon.

Use the correct nuclide notation to write a symbol equation for this decay process.

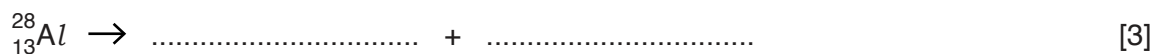

- (ii) State the meaning of the term *isotope*.

.....

 [1]

- (iii) The isotope ${}_{13}^{28}\text{Al}$ has a half-life of 135 seconds. The decay of a 1 g sample of ${}_{13}^{28}\text{Al}$ is observed.

Calculate the time, in seconds, before there is only 0.125 g of ${}_{13}^{28}\text{Al}$ remaining.

Show your working.

time = seconds [2]

- (b) The boiling point of aluminium is 2519 °C. When liquid aluminium boils, energy is required to turn it into a gas. While it is boiling, the temperature of the aluminium remains the same.

Explain why the temperature of the aluminium remains the same while it is boiling.

Use the term *latent heat of vaporisation* in your answer.

.....

 [2]

- (c) (i) Complete the sentence below using the words or phrases from the list.

Each word or phrase may be used once, more than once or not at all.

decreases does not change increases

When a block of aluminium is heated, the mass of the block

..... , the volume of the block

..... and the density of the block

..... . [2]

- (ii) A student carries out an experiment to find the specific heat capacity of a 2 kg block of aluminium.

She finds that 40 kJ of thermal energy is needed to raise the temperature of the block by 21 °C.

Calculate the specific heat capacity of aluminium.

State the formula you use and show your working.

formula

working

specific heat capacity = J/kg °C [2]

10 (a) Table 10.1 shows the number of chromosomes in the nuclei of body cells in different organisms.

Table 10.1

organism	number of chromosomes
chicken	78
hedgehog	90
mosquito	6
pineapple	50

(i) Use the information in Table 10.1 to state the number of chromosomes in each nucleus of the pineapple cells resulting from cell division by **mitosis**.

..... [1]

(ii) Use the information in Table 10.1 to state the number of chromosomes in each nucleus of the hedgehog cells resulting from cell division by **meiosis**.

..... [1]

(b) (i) Explain why meiosis is necessary for sexual reproduction.

.....
 [1]

(ii) State **one** advantage and **one** disadvantage of sexual reproduction.

advantage

.....

disadvantage

..... [2]

- 11 (a) Table 11.1 shows the raw materials that are used to produce four useful substances.

Complete Table 11.1 by choosing useful substances from the list.

ammonia bromine calcium oxide chlorine
 gasoline iron nylon sulfuric acid

Table 11.1

raw materials	useful substance produced
hydrocarbons, air and steam	
limestone	
concentrated aqueous sodium chloride	
petroleum	

[4]

- (b) Petroleum is a mixture of alkanes.

Alkanes are changed into alkenes by cracking.

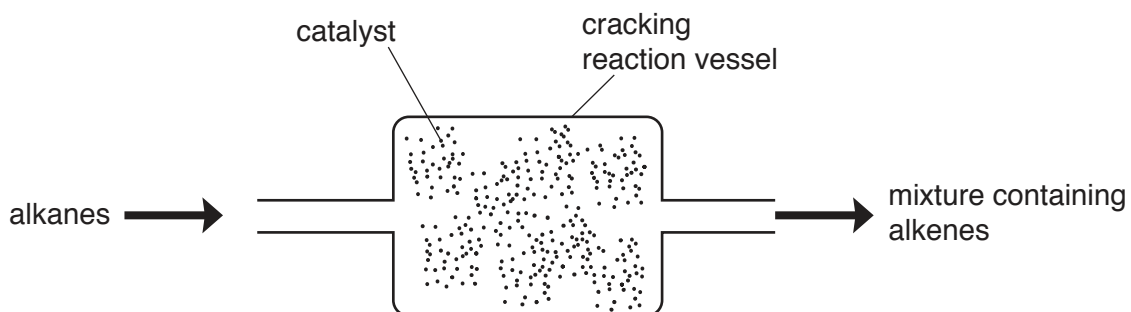

Fig. 11.1

- (i) The cracking reaction in Fig. 11.1 uses a catalyst.

State **one** other reaction condition used in the reaction vessel.

.....[1]

- (ii) Suggest how bromine solution can be used to show that the process in Fig. 11.1 produces alkenes.

.....

.....

.....

.....

.....[3]

- (iii) Complete Fig. 11.2 to show how the outer-shell electrons are arranged in one molecule of ethene.

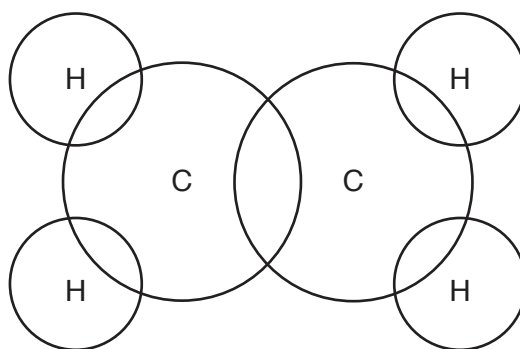

Fig. 11.2

[2]

- (iv) Ethene is involved in several different **addition** reactions.

Identify **two** compounds that are produced in these reactions.

1

2

[2]

- 12 (a) Fig. 12.1 shows a bicycle with a front lamp **P** and a rear lamp **Q** powered by the same 9.0V battery.

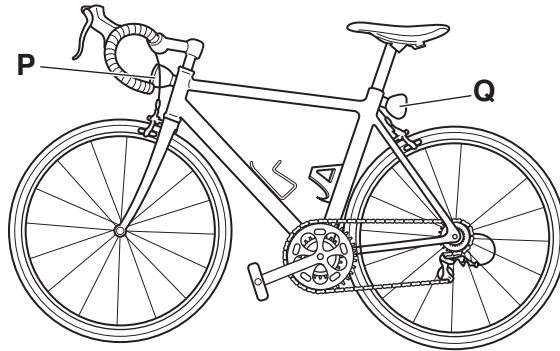

Fig. 12.1

Fig. 12.2 is a circuit diagram to show how the lamps are connected.

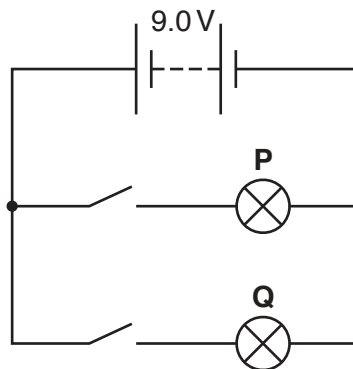

Fig. 12.2

- (i) Lamp **P** has a resistance of $12\ \Omega$ and lamp **Q** has a resistance of $6.0\ \Omega$.

Calculate the combined resistance of the two lamps in this circuit.

Show your working.

resistance = Ω [2]

- (ii) Calculate the power consumption of lamp **P** when lit.
 State any formulae you use and show all your working.

formulae

working

power = W [3]

- (b) Fig. 12.3 shows the cyclist approaching a road junction. A car is waiting at the road junction.

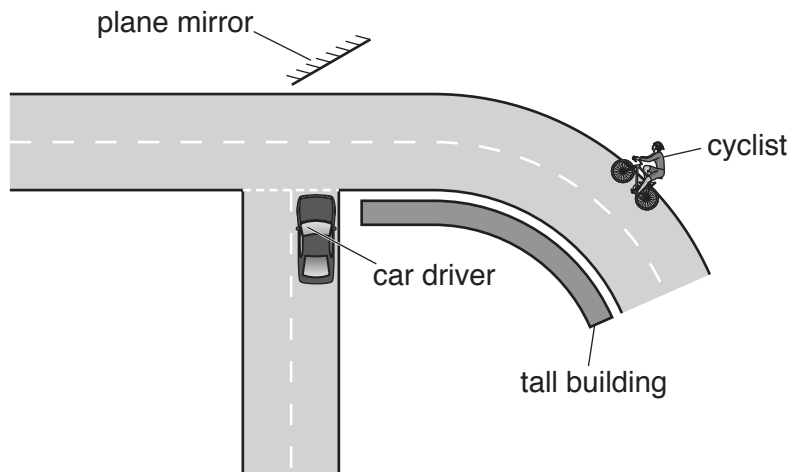

Fig. 12.3

A plane mirror that allows the car driver to see the cyclist is placed near the junction.

On Fig. 12.3, draw a ray diagram to show how the driver can see the cyclist in the mirror. Label the angle of incidence, i , and the angle of reflection, r . [2]

- (c) A different bicycle has a generator to supply electricity for the bicycle lights. Fig. 12.4 shows the generator.

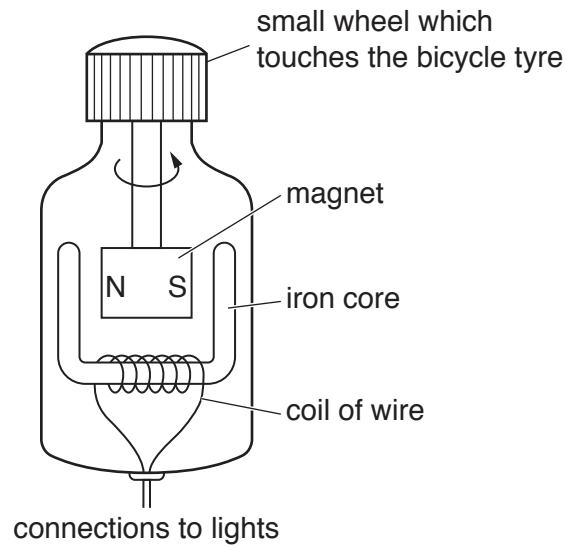

Fig. 12.4

A small wheel which touches the bicycle tyre turns the magnet inside the iron core.

The changing magnetic field induces an e.m.f. in the coil.

- (i) State what the abbreviation e.m.f. stands for.

.....[1]

- (ii) State **one** way in which the size of the induced e.m.f. can be increased.

.....
[1]

(d) The generator is noisy and emits sound waves that pass through the air.

(i) The sound waves pass through the air as a series of compressions (C) and rarefactions (R).

Fig. 12.5 shows the positions of the compressions and rarefactions as the sound wave passes through the air.



Fig. 12.5

On Fig. 12.5, mark **one** wavelength with a double headed arrow (\leftrightarrow). [1]

(ii) Suggest how the distance between two compressions changes if the frequency of the sound wave decreases.

.....
[1]

13 A student investigates the response of a plant shoot to light.

The student shines light onto one side of the shoot for five days.

(a) Fig. 13.1 shows a diagram of the student's observations.

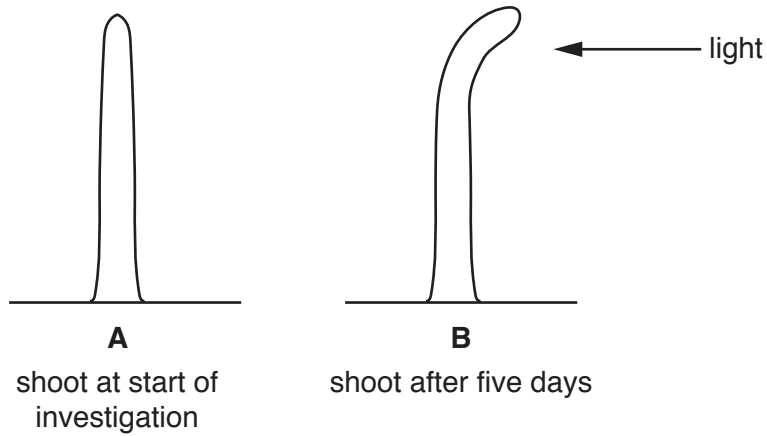

Fig. 13.1

(i) State the name of the hormone that causes the response seen in Fig. 13.1.

.....[1]

(ii) Explain how the hormone in your answer to (a)(i) causes the shoot to bend towards the light.

.....

[2]

(b) The student repeats the investigation with the shoot shown in Fig. 13.2.

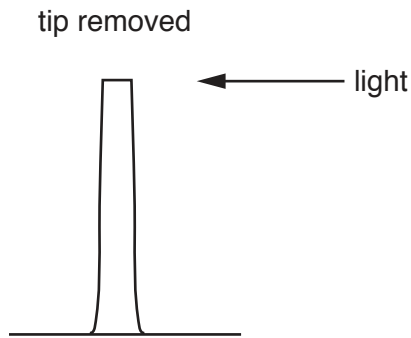

Fig. 13.2

Predict **and** explain the results observed after five days.

.....

.....

.....[2]

(c) (i) The response of a shoot to light is an example of sensitivity, one of the characteristics of living organisms.

Use words from the list to define the term *sensitivity*.

Each word may be used once, more than once or not at all.

- atmosphere environment hormones proteins**
- soil responses water**

Sensitivity is the ability to detect or sense changes in the
 and to make [2]

(ii) Circle **one** other characteristic of all living organisms.

- breathing eating growth**
- meiosis talking sleeping**

[1]

BLANK PAGE

Permission to reproduce items where third-party owned material protected by copyright is included has been sought and cleared where possible. Every reasonable effort has been made by the publisher (UCLES) to trace copyright holders, but if any items requiring clearance have unwittingly been included, the publisher will be pleased to make amends at the earliest possible opportunity.

To avoid the issue of disclosure of answer-related information to candidates, all copyright acknowledgements are reproduced online in the Cambridge International Examinations Copyright Acknowledgements Booklet. This is produced for each series of examinations and is freely available to download at www.cie.org.uk after the live examination series.

Cambridge International Examinations is part of the Cambridge Assessment Group. Cambridge Assessment is the brand name of University of Cambridge Local Examinations Syndicate (UCLES), which is itself a department of the University of Cambridge.

The Periodic Table of Elements

		Group															
I	II	III	IV	V	VI	VII	VIII						VIII				
3 Li lithium 7	4 Be beryllium 9	1 H hydrogen 1	5 B boron 11	6 C carbon 12	7 N nitrogen 14	8 O oxygen 16	9 F fluorine 19	10 Ne neon 20						18 Ar argon 40			
11 Na sodium 23	12 Mg magnesium 24	Key atomic number atomic symbol name relative atomic mass		13 Al aluminium 27	14 Si silicon 28	15 P phosphorus 31	16 S sulfur 32	17 Cl chlorine 35.5						36 Kr krypton 84			
19 K potassium 39	20 Ca calcium 40	21 Sc scandium 45	22 Ti titanium 48	23 V vanadium 51	24 Cr chromium 52	25 Mn manganese 55	26 Fe iron 56	27 Co cobalt 59	28 Ni nickel 59	29 Cu copper 64	30 Zn zinc 65	31 Ga gallium 70	32 Ge germanium 73	33 As arsenic 75	34 Se selenium 79	35 Br bromine 80	36 Kr krypton 84
37 Rb rubidium 85	38 Sr strontium 88	39 Y yttrium 89	40 Zr zirconium 91	41 Nb niobium 93	42 Mo molybdenum 96	43 Tc technetium —	44 Ru ruthenium 101	45 Rh rhodium 103	46 Pd palladium 106	47 Ag silver 108	48 Cd cadmium 112	49 In indium 115	50 Sn tin 119	51 Sb antimony 122	52 Te tellurium 128	53 I iodine 127	54 Xe xenon 131
55 Cs caesium 133	56 Ba barium 137	57–71 lanthanoids	72 Hf hafnium 178	73 Ta tantalum 181	74 W tungsten 184	75 Re rhenium 186	76 Os osmium 190	77 Ir iridium 192	78 Pt platinum 195	79 Au gold 197	80 Hg mercury 201	81 Tl thallium 204	82 Pb lead 207	83 Bi bismuth 209	84 Po polonium —	85 At astatine —	86 Rn radon —
87 Fr francium —	88 Ra radium —	89–103 actinoids	104 Rf rutherfordium —	105 Db dubnium —	106 Sg seaborgium —	107 Bh bohrium —	108 Hs hassium —	109 Mt meitnerium —	110 Ds darmstadtium —	111 Rg roentgenium —	112 Cn copernicium —	114 Fl flerovium —	116 Lv livermorium —				

lanthanoids

57 La lanthanum 139	58 Ce cerium 140	59 Pr praseodymium 141	60 Nd neodymium 144	61 Pm promethium —	62 Sm samarium 150	63 Eu europium 152	64 Gd gadolinium 157	65 Tb terbium 159	66 Dy dysprosium 163	67 Ho holmium 165	68 Er erbium 167	69 Tm thulium 169	70 Yb ytterbium 173	71 Lu lutetium 175
89 Ac actinium —	90 Th thorium 232	91 Pa protactinium 231	92 U uranium 238	93 Np neptunium —	94 Pu plutonium —	95 Am americium —	96 Cm curium —	97 Bk berkelium —	98 Cf californium —	99 Es einsteinium —	100 Fm fermium —	101 Md mendelevium —	102 No nobelium —	103 Lr lawrencium —

actinoids

The volume of one mole of any gas is 24 dm³ at room temperature and pressure (r.t.p.).